

Gußabsperrventil (Durchgang) mit Löt- oder Schweißanschluss
Cast Iron Shutoff Valve (connecting passage)
with solder/ welding connection

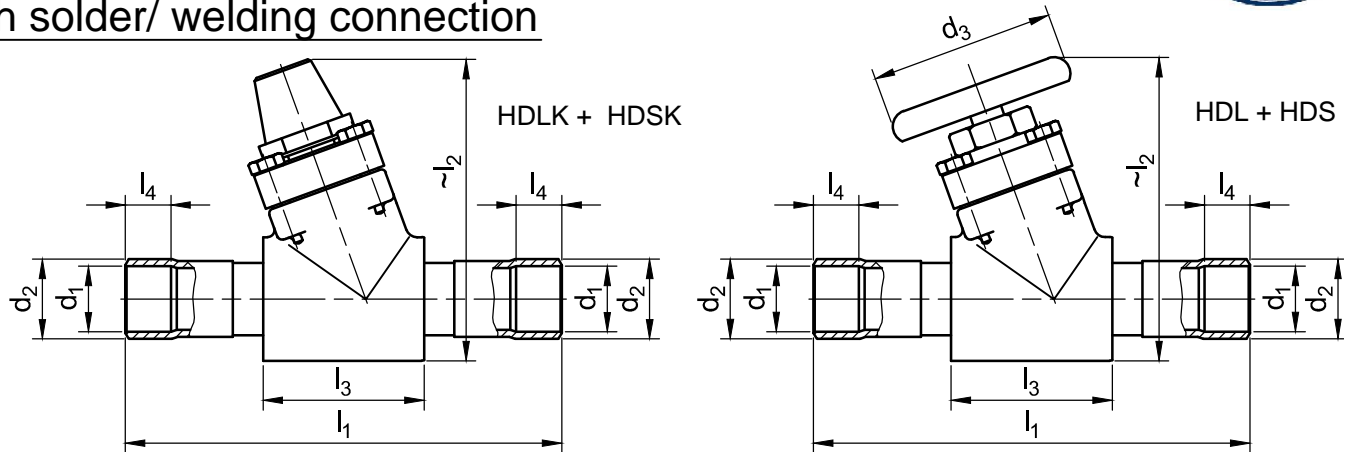

Schweißanschluss - welding connection	Order Number	FAS-Typ	d ₁	d ₂	d ₃	l ₁	~l ₂	l ₃	l ₄	Kv m ³ /h
	804 511 000	HDSK25	28	35	-	198	140	70	20	9,7
	804 513 000	HDSK32	35	43	-	229	204	113	25	31,0
	804 514 000	HDSK40	42	50	-	229	204	113	25	35,0
	804 515 000	HDSK50	54	62	-	259	215	123	30	44,0
	804 516 000	HDSK65	64	76	-	314	245	158	35	62,0
	804 519 000	HDSK80	80	89	-	372	320	196	40	91,0
	804 611 000	HDS25	28	35	85	186	130	70	20	9,7
	804 613 000	HDS32	35	43	140	230	194	113	25	31,0
	804 614 000	HDS40	42	50	140	230	194	113	25	35,
	804 615 000	HDS50	54	62	140	260	205	123	30	44,0
	804 616 000	HDS65	64	76	180	314	235	158	35	62,0
804 619 000	HDS80	80	89	180	372	310	196	40	91,0	
Lötanschluss - soldering connection	Order Number	FAS-Typ	d ₁	d ₂	d ₄	l ₁	~l ₂	l ₃	l ₄	Kv m ³ /h
	804 711 000	HDLK28	28	-	-	198	140	70	20	9,7
	804 713 000	HDLK35	35	-	-	230	204	113	25	31,0
	804 714 000	HDLK42	42	-	-	230	204	113	25	35,0
	804 715 000	HDLK54	54	-	-	260	215	123	30	44,0
	804 716 000	HDLK64	64	-	-	314	245	158	35	62,0
	804 717 000	HDLK70	70	-	-	314	245	158	35	62,0
	804 718 000	HDLK76	76	-	-	372	320	196	40	91,0
	804 719 000	HDLK80	80	-	-	372	320	196	40	91,0
	804 811 000	HDL28	28	-	85	186	130	70	20	9,7
	804 813 000	HDL35	34	-	140	230	194	113	25	31,0
	804 814 000	HDL42	42	-	140	230	194	113	25	35,0
	804 815 000	HDL54	54	-	140	260	205	123	30	44,0
	804 816 000	HDL64	64	-	180	314	235	158	35	62,0
	804 817 000	HDL70	70	-	180	314	235	158	35	62,0
	804 818 000	HDL76	76	-	200	372	310	196	40	91,0
	804 819 000	HDL80	80	-	200	372	310	196	40	91,0

Reparaturset erhältlich
 repair set available

Dichtungssatz erhältlich
 gasket set available

Kv-Wert (Wasserdurchfluss bei einer Druckdifferenz von 1 bar)
 Kv-value (water flow with a difference of pressure of 1 bar)